



# Function

**GTEM** stands for Gigahertz Transverse Electro Magnetic. This special type of cell has the advantage of having no cut-off frequency as do other types of TEM waveguides.

In principle, the GTEM cell is a coaxial line expanding pyramidally and having an impedance of  $50 \Omega$ . At its end, the line is terminated by a combination of termination resistors and RF absorbers designed and constructed to match the above mentioned impedance.

**Electromagnetic fields** can be generated by the connection of an RF generator and power amplifier to the feeding point of the GTEM. TEM waves start to propagate between the septum and outer conductor (cell body).

The electromagnetic field intensity is directly related to both the supplied input power and to the distance between septum and outer conductor.

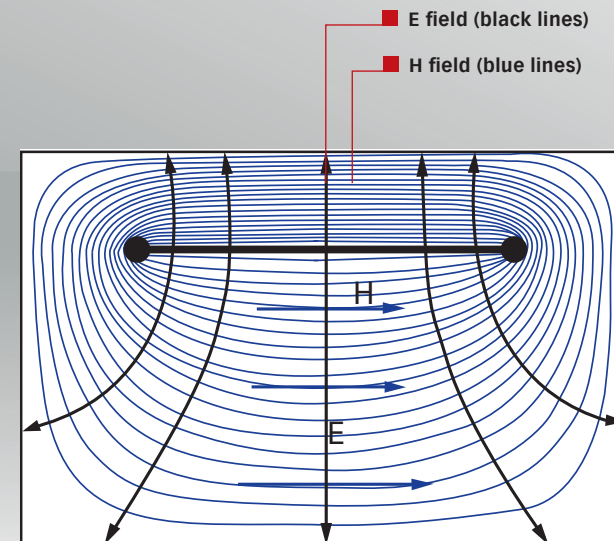
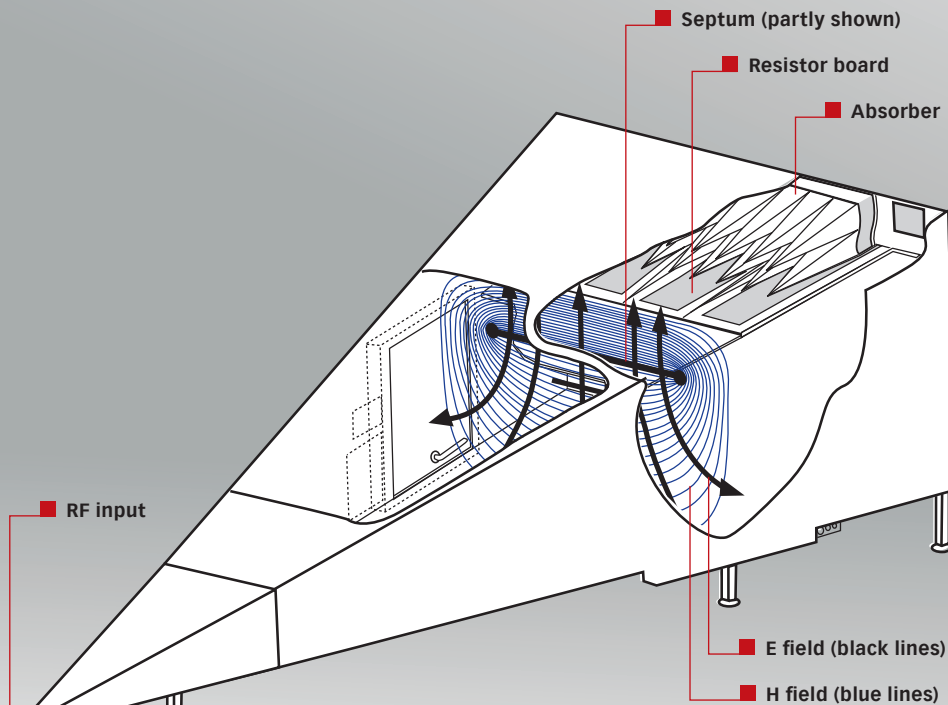

# Calculation of required input power

- The field strength is typically independent from the frequency.
- The frequency range is from DC to 20 GHz. The best performance is achieved in the range 80 to 1000 MHz.
- FAR (Fully Anechoic Room) requires an amplifier with 100 W for 10 V/m. A GTEM 750 requires only 7.3 W.
- A decreased septum height provides higher field strength (applicable for small EUTs only).

## Example of power requirement for 10 V/m at septum height 0.75 m

Field strength	E	= 10 V/m
Septum height	h	= 0.75 m
Input impedance	Z	= 50 Ω
Flatness	F	= 3 dB = 2
Modulation	M	= 3.24 (for AM 80% as required for IEC 61000-4-3)
	M	= 1 (for AM 80% as required for Automotive and MIL standards)

**Power**  $P = (E \cdot h)^2 / Z \cdot F \cdot M$

**Example**  $P = (10 \text{ V/m} \cdot 0.75 \text{ m})^2 / 50 \Omega \cdot 2 \cdot 3.24 = 7.3 \text{ W} = 38.6 \text{ dBm}$

## Example of a generated field strength with 7.3 W input power at septum height 0.75 m

**Field strength**  $E = \sqrt{(P / (M \cdot F) \cdot Z) / h}$

**Example**  $E = \sqrt{(7.3 \text{ W} / (3.24 \cdot 2) \cdot 50 \Omega) / 0.75 \text{ m}} = 10 \text{ V/m}$

## Example of required input power for 10 V/m in relation to the septum height

- h = 2.0 m, P = 51.8 W (16 W for M = 1)
- h = 1.5 m, P = 29.2 W (9 W for M = 1)
- h = 1.0 m, P = 13.0 W (4 W for M = 1)
- h = 0.5 m, P = 3.2 W (1 W for M = 1)

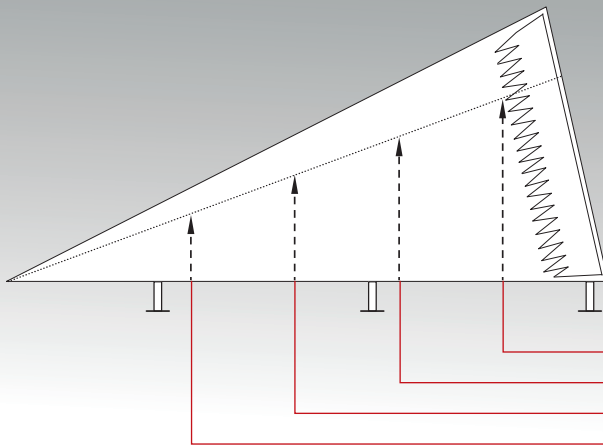

# TEM mode and uniform-area

IEC 61000-4-20 – Electromagnetic compatibility (EMC) – Part 4-20: Testing and measurement techniques – Emission and immunity testing in transverse electromagnetic (TEM) waveguides – is published as a basic standard which sets the requirements for performing EMC testing in waveguides. It describes the TEM mode verification as an elementary requirement for qualifying the waveguide. This procedure requires a field generating setup and an isotropic 3-axis field probe. The number and position of the points to be verified is related to the GTEM size as shown in the table below. The procedure verifies the TEM mode and also determines the size of the uniform area, maximum EUT size and the required power for a given field strength for immunity testing.

GTEM cell, cross-section of the generated field and example of point positioning

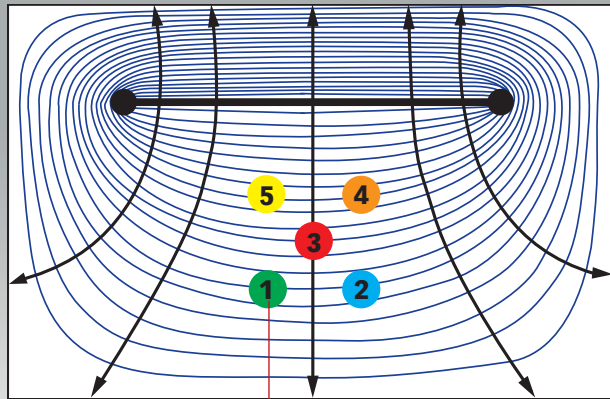

■ Calibration points (quantity in relation of the size of the area)

GTEM size, max. septum height	250	500	750	1000	1250	1500	1750	2000
Length d of one side of uniform area in mm	83	167	250	333	416	500	583	666
Septum height at marker position in mm	217	433	650	866	1083	1299	1516	1732
Measuring points	1	5	5	5	5	9	9	9

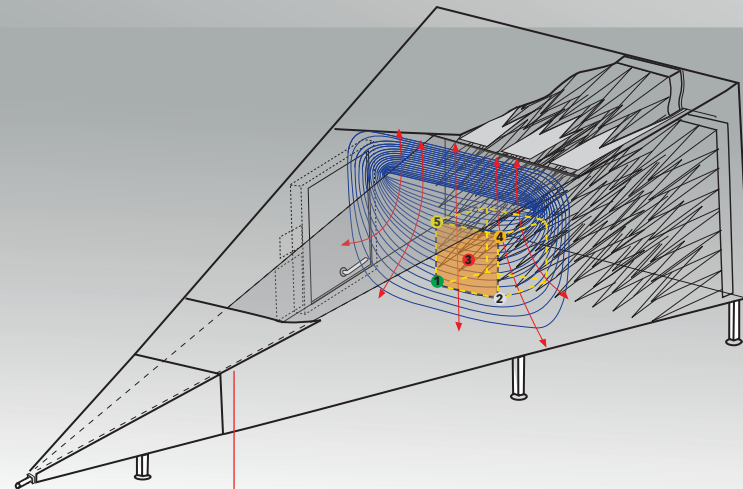

■ Uniform area (calibration points shown in

# Immunity testing

A typical setup for immunity testing consists of:

- Test House Software
- Signal generator
- Power amplifier
- Directional coupler
- Power meter
- GTEM
- Field probe (for calibration procedure only)

Example of setup 9 kHz to 1 GHz with one power amplifier

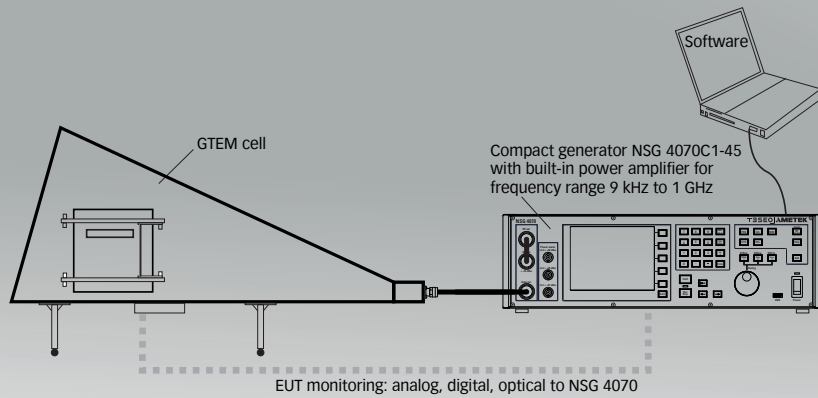

Example of test setup 9 kHz to 6 GHz with three power amplifiers and measuring receiver

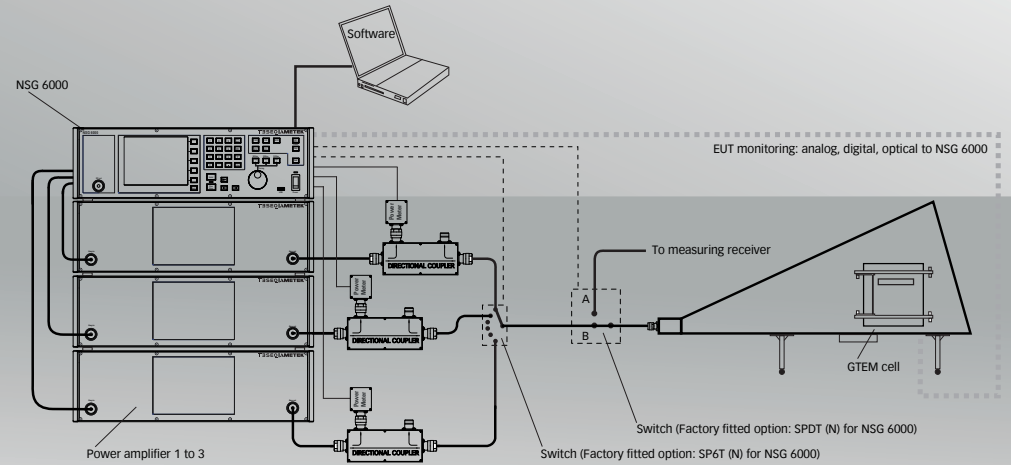

# Emissions measurement

EUT radiated emissions are measured as a voltage at the feeding point of the GTEM. Measurements of at least three orthogonal EUT positions are required and the data is converted to a comparable field strength on an OATS (Open Area Test Site) by means of a GTEM correlation algorithm. Optional software offers this algorithm.

## Simplified flow chart of the correlation procedure

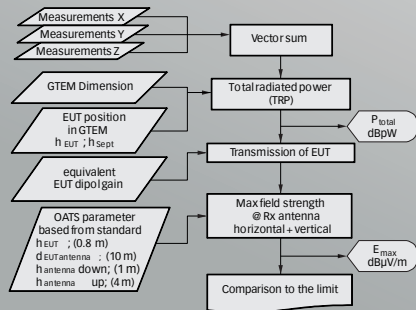



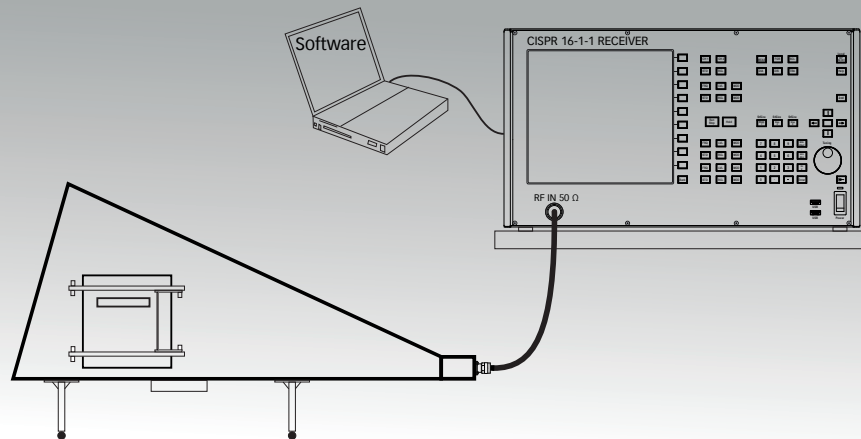



## Emissions measurement setup example

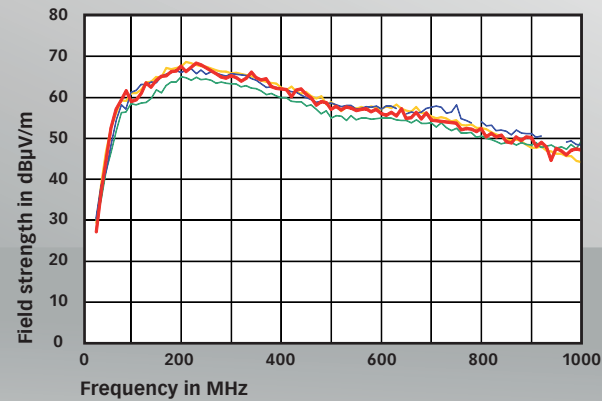

## Comparison of Teseq VSQ 1000 reference source measured in four different test facilities

- Semi-anechoic Chamber of the Federal Network Agency Germany, 10 m distance, maximum values in horizontal and vertical polarization
- Open Area Test Site Seibersdorf, Austria, 10 m distance, maximum values in horizontal and vertical polarization
- Open Area Test Site Capel, United Kingdom, 10 m distance, maximum values in horizontal and vertical polarization
- GTEM 1750, Teseq Berlin, Germany

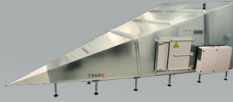
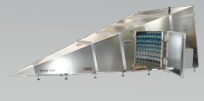
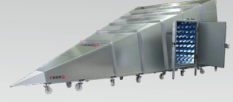

	Picture	Frequency range / frequency range according IEC/EN 61000-4-20	Immunity/emission testing	Max. septum height in mm	Max. RF input power inW	Input connector type N, 50 Ω	VSWR DC to 18 GHz	Dimension in m	Weight i kg/number of sup-ports	Max. field strength in V/m with modulation (IEC 61000-4-3)	Max. field strength in V/m with modulation (Automotive, MIL)	Max. EUT size in m	Def. 0 to 6 dB EUT size in m	Door size in m	Door switch	Shielded window size in m	Number of fans	Shielding effectiveness (30 MHz to 3 GHz)	2 AC filter 16 A, 1 AC socket, line safety switch, earth leakage circuit breaker	Switchable illumination	Feed through panel with 3x N and optical feed through tube	Optional filter solutions for AC, DC and data
GTEM 250		DC to 20 GHz / 30 to 3000 MHz	■	250	100	■	<1.25:1	L: 1.23 W: 0.66 H: 0.54	45 / 3	128	230	L: 0.20 W: 0.20 H: 0.15	L: 0.083 W: 0.083 H: 0.083	L: 0.20 H: 0.13	-	L: 0.12 H: 0.07	1	>60 dB, typ. >80 dB	-	-	-	□
GTEM 500		DC to 20 GHz / 30 to 3000 MHz	■	500	400	■	<1.45:1	L: 2.95 W: 1.48 H: 1.61	242 / 3	128	230	L: 0.41 W: 0.41 H: 0.31	L: 0.167 W: 0.167 H: 0.167	L: 0.44 H: 0.38	■	L: 0.3 H: 0.1	2	>60 dB, typ. >80 dB	■	■	■	□
GTEM 750		DC to 20 GHz / 30 to 3000 MHz	■	750	500	■	<1.45:1	L: 3.95 W: 2.02 H: 1.95	390 / 6	96	172	L: 0.62 W: 0.62 H: 0.49	L: 0.25 W: 0.25 H: 0.25	L: 0.65 H: 0.50	■	L: 0.3 H: 0.1	2	>60 dB, typ. >80 dB	■	■	■	□
GTEM 1000		DC to 20 GHz / 30 to 3000 MHz	■	1000	1000	■	<1.45:1	L: 4.95 W: 2.54 H: 2.30	790 / 8	101	183	L: 0.74 W: 0.74 H: 0.66	L: 0.333 W: 0.333 H: 0.333	L: 0.48 H: 0.68	■	L: 0.3 H: 0.1	5	>60 dB, typ. >80 dB	■	■	■	□
GTEM 1250		DC to 20 GHz / 30 to 3000 MHz	■	1250	1000	■	<1.45:1	L: 5.95 W: 3.06 H: 2.52	1150 / 16	81	146	L: 0.93 W: 0.93 H: 0.83	L: 0.416 W: 0.416 H: 0.416	L: 0.85 H: 0.85	■	L: 0.3 H: 0.1	5	>60 dB, typ. >80 dB	■	■	■	□
GTEM 1500		DC to 20 GHz / 30 to 3000 MHz	■	1500	1000	■	<1.6:1 (typ. <1.45:1)	L: 6.87 W: 3.63 H: 2.54	1470 / 25	68	122	L: 1.11 W: 1.11 H: 0.99	L: 0.5 W: 0.5 H: 0.5	L: 0.99 H: 1.29	■	L: 0.3 H: 0.1	5	>60 dB, typ. >80 dB	■	■	■	□
GTEM 1750		DC to 20 GHz / 30 to 3000 MHz	■	1750	1000	■	<1.8:1 (typ. <1.45:1)	L: 7.95 W: 4.10 H: 2.90	1800 / 28	58	104	L: 1.32 W: 1.32 H: 1.16	L: 0.583 W: 0.583 H: 0.583	L: 1.03 H: 1.54	■	L: 0.3 H: 0.1	5	>60 dB, typ. >80 dB	■	■	■	□
GTEM 2000		DC to 20 GHz / 30 to 3000 MHz	■	2000	1000	■	<1.8:1 (typ. <1.45:1)	L: 8.95 W: 4.62 H: 3.24	2500 / 34	51	91	L: 1.50 W: 1.50 H: 1.32	L: 0.666 W: 0.666 H: 0.666	L: 1.03 H: 1.54	■	L: 0.3 H: 0.1	6	>60 dB, typ. >80 dB	■	■	■	□

■ standard

\*) option

□ on request, see also next page

- not applicable

	Option for GTEM 250	Option for GTEM 500, GTEM 750	Option for GTEM 1000-2000	2 AC filter 16 A, 1 AC socket, line safety switch, earth leakage circuit breaker	4 AC filter 32 A, 1 AC socket 3 phase, line safety switch, earth leakage circuit breaker	Number of AC filters / current rating	Number of DC filters / current rating	Number of line filters, max 15 A, 200 VDC, banana sockets	Number of line filters, max 5 A, 200 VDC /Sub-D connector type	Connector type	Option for EUT-BOX 1/ 3/ 31 only	Placed on Media S	Placed on Media 3	Placed on Media 4	Comment
SIA 250	■			-	-	-	-	10	4 / 9 pins	4 mm banana, Sub-D 9 pins	-	-	-	-	User can easily replace the filter box as needed
SIB 250	■			-	-	-	-	2	37 / 37 pins	4 mm banana, Sub-D 37 pins	-	-	-	-	User can easily replace the filter box as needed
SIC 250	■			-	-	2x 16 A	-	6	9 / 9 pins	4 mm banana, Sub-D 9 pins, IEC C14	-	-	-	-	User can easily replace the filter box as needed
SID 250	■			-	-	2x 16 A	-	2	15 / 15 pins	4 mm banana, Sub-D 15 pins, IEC C14	-	-	-	-	User can easily replace the filter box as needed
EUT-BOX 251	■			-	-	4x 16 A	-	-	-	4 mm banana	-	-	-	-	User can easily replace the filter box as needed
EUT-BOX 1	-	-	■	■	-	2x 16 A	-	-	-	Country specific	-	-	-	-	Standard scope of delivery
DC 1	-	■	■	-	-	-	2x 10 A	-	-	4 mm banana	■	-	-	-	Only once per EUT-BOX 1/3/31, not combinable with AC 1
AC 1	-	■	■	-	-	2x 16 A	-	-	-	4 mm banana	■	-	-	-	Only once per EUT-BOX 1/3/31, not combinable with DC 1
EUT-BOX 2-30	-	■	■	-	-	2x 30 A	like AC	-	-	4 mm banana	-	■	-	-	Placement on Media S in relation to other options
EUT-BOX 3	-	-	■	-	■	4x 16 A	-	-	-	CEE, 32 A version	-	-	-	-	Option is in addition to the EUT-BOX 1
EUT-BOX 31	-	■	■	-	■	4x 16 A	-	-	-	CEE, 32 A version	-	-	-	-	Option replaces the EUT-BOX 1
EUT-BOX 4-10	-	■	■	-	-	-	4x 10 A	-	-	4 mm banana	-	■	-	-	Placement on Media S in relation to other options
EUT-BOX 4-16	-	■	■	-	-	4x 16 A	-	-	-	4 mm banana	-	■	-	-	Placement on Media S in relation to other options
EUT-BOX 4-32	-	■	■	-	-	4x 32 A	-	-	-	4 mm banana	-	■	-	-	Placement on Media S in relation to other options
EUT-BOX 5	-	-	■	-	-	2x 63 A	-	-	-	6 mm banana	-	-	-	■	-
EUT-BOX 6	-	-	■	-	-	10x 63 A	-	-	-	6 mm banana	-	-	■	□	-
EUT-BOX 7	-	-	■	-	-	2x 200 A	-	-	-	wing terminals	-	-	-	■	-
SIF M	-	■	■	-	-	-	-	-	25 / 25 pins	Sub-D 25 pins	-	■	□	□	Placement on Media S in relation to other options
RS232 Filter	-	■	■	-	-	-	-	-	9 / 9 pins	Sub-D 9 pins	-	■	□	□	Placement on Media S in relation to other options
USB Filter	-	■	■	-	-	-	-	-	-	USB "A" type	-	■	□	□	Placement on Media S in relation to other options
CAN BUS Filter	-	■	■	-	-	-	-	-	-	Sub-D 9 pins	-	■	□	□	Placement on Media S in relation to other options

■ applicable    □ on request    - not applicable

# XYZ Manipulator

**XYZ Manipulators** are ideal for easily rotating the EUT into the three required orthogonal axis positions. The manual versions (MPH) are installed inside the cell while the remote controlled versions (MPC) have a motor underneath the floor of the cell. GTEMs can be supplied with removable panels to allow the future installation of XYZ Manipulators. The MPC requires factory installation. See also the XYZ Manipulator datasheet for more details.

Position of XYZ Manipulator inside the GTEM cell

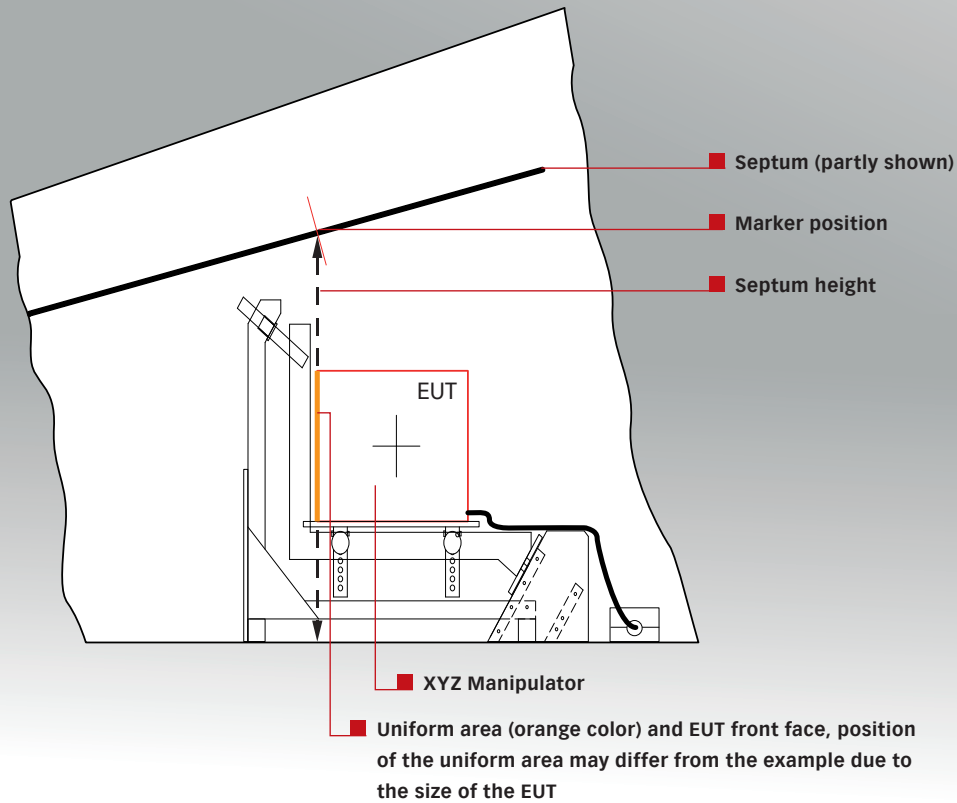

XYZ Manipulator, example inside GTEM

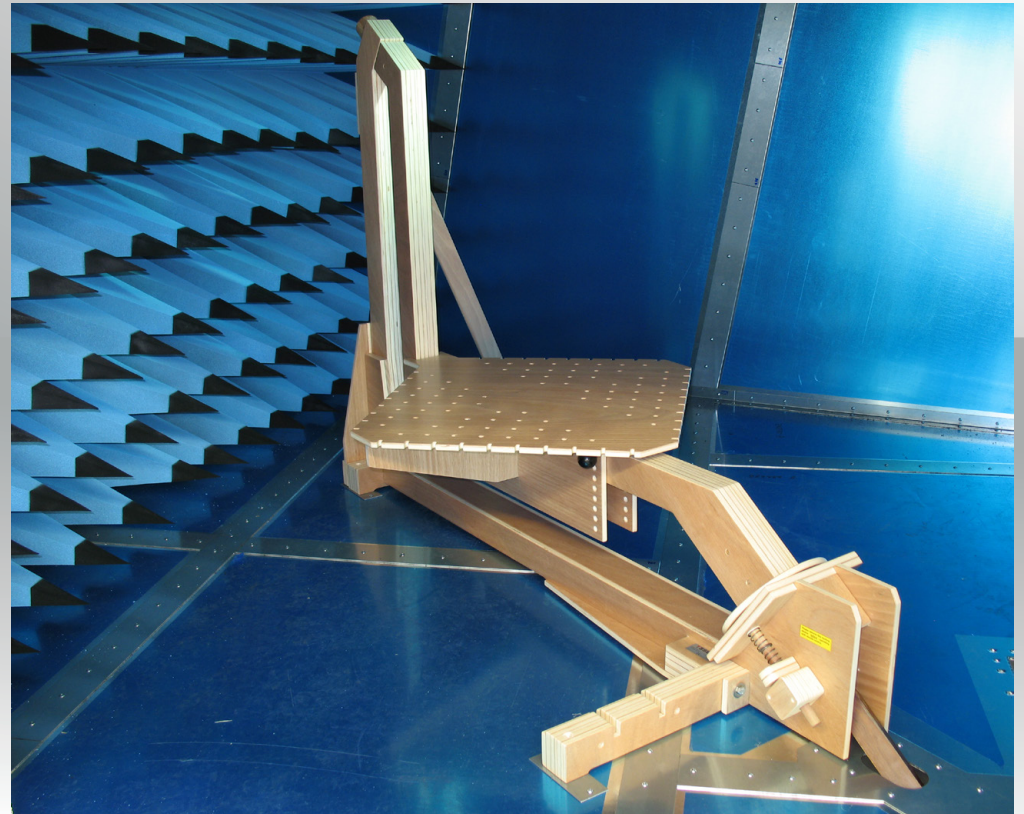

# Integrated circuit (IC) testing

## Emissions measurements

The standards SAE J1752/3 and IEC 61967-2 define a method for measuring the electromagnetic radiation from an IC (integrated circuit) in the frequency range 150 kHz to 1 GHz. The IC itself is mounted on a shielded test board that is clamped to a special hole in the top of the TEM cell. Except for the IC, all the interface wiring and other required components are placed on the outside of the test board which becomes part of the cell wall. A spectrum analyzer or measurement receiver is connected to the GTEM and measures the RF emissions from the integrated circuit.

## Immunity testing

The test board described above can also be used for IC immunity testing with a GTEM cell. The standard IEC 62132-2 specifies the immunity test method for integrated circuits in the frequency range 150 kHz to 1 GHz.

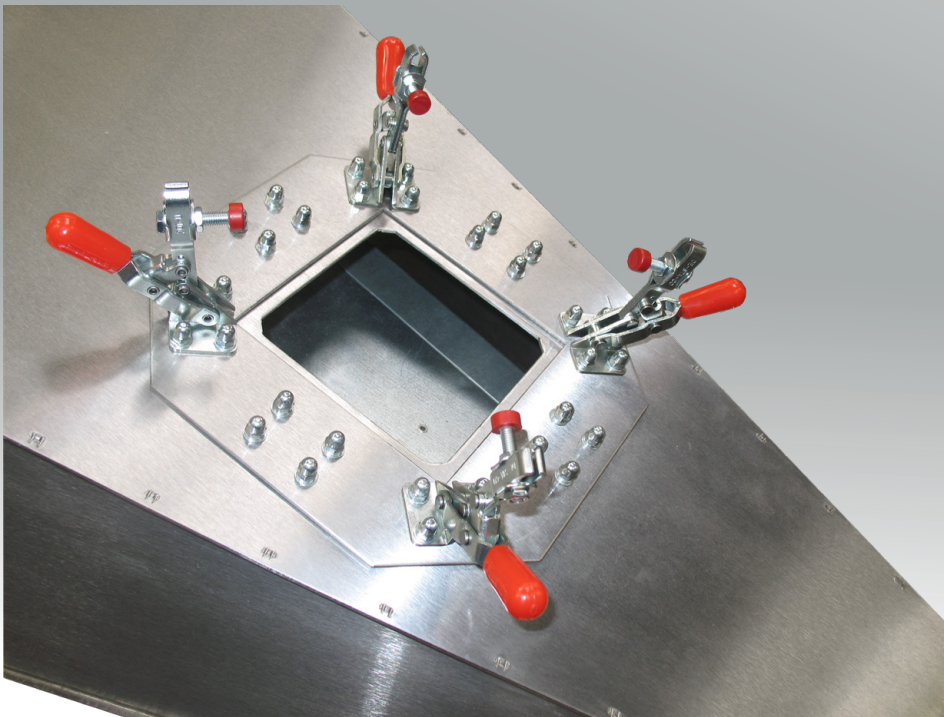

## Product range for IC testing

GTEM type	Description
<b>GTEM 250-R-SAE</b>	GTEM with septum height 250 mm, door side right, max. RF input power 100 W, with special opening to test IC on approx. 45 mm septum height, meets SAE 1752/3, IEC 62132-2 and IEC 61967-2, shielded window in door, optical feed through, empty filter box for individual use, desktop model
<b>GTEM 250A-SAE-R</b>	GTEM with septum height 250 mm, low VSWR, door side right, max. RF input power 100 W, with special opening to test IC on approx. 45 mm septum height, meets SAE 1752/3, IEC 62132-2 and IEC 61967-2, shielded window in door, optical feed through, desktop model
<b>GTEM 500 to GTEM 2000</b>	Option for GTEM 500 to GTEM 2000: Included input section gets a special opening to test IC on approx. 45 mm septum height, meets SAE 1752/3, IEC 62132-2 and IEC 61967-2, order only with GTEM