



HV-AN 1uH-800-VW80300 HIGH VOLTAGE ARTIFICIAL NETWORK



- 1 μ H HV-AN with 800 Amps
- HV-AN as defined in VW 80300
- Solution for high current and voltage

The artificial network HV-AN 1uH-800-VW80300 offers a solution for high current and high voltage connections to the EUTs as proposed in VW 80300. The AN is used to simulate the impedance of a vehicle harness to determine the behavior of EUT.

The combination of two networks in one shielded box allows testing of high voltage connections. The shielded metal housing SME HV-AN 500 is designed to accommodate two HV-AN 1 μ H-800-VW80300.

The test setup with HV-AN 1uH-800-VW80300 is intended for tests with fast processes on the HV on-board network. Die HV-AN 1uH-800-VW80300 simulates the complex impedances of the on-board network for the test. The shields of the HV cables or the HV connectors are connected to the shielded housing or the shielding hood. The interference signals are coupled in via the N-socket of the mains simulation.

Example measurement setup

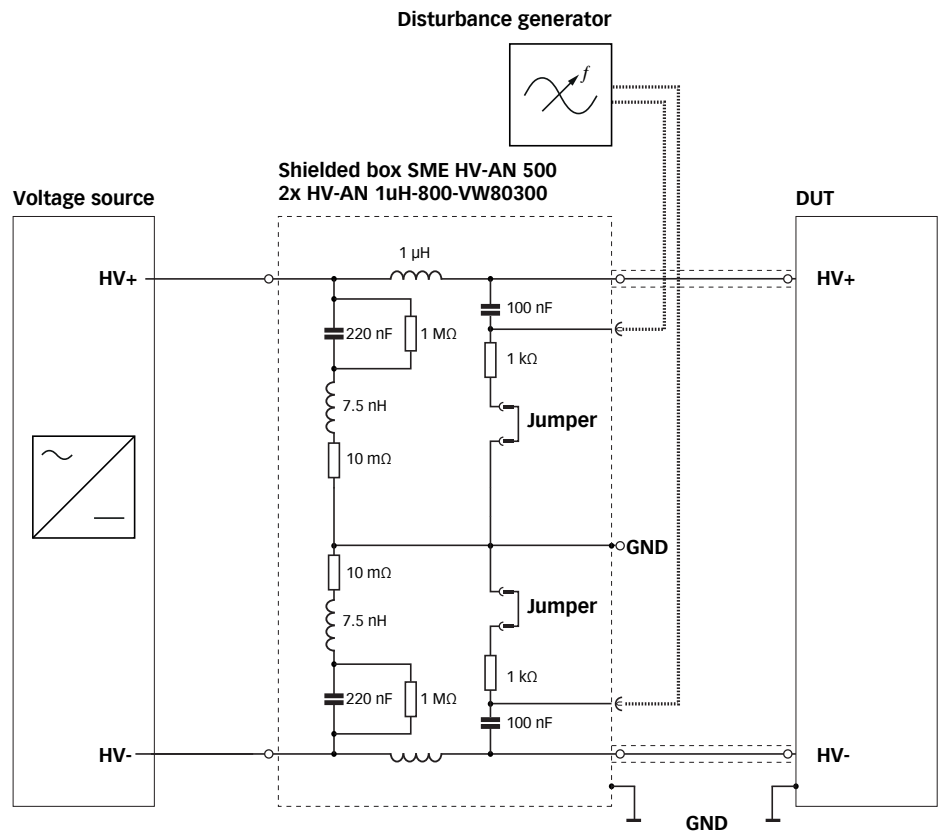

HV-AN 1uH-800-VW80300 inserted in option SME HV-AN-500

HV-AN 1uH-800-VW80300

HIGH VOLTAGE ARTIFICIAL NETWORK

Technical specifications

Frequency range:	100 kHz to 100 MHz
Power ratings (EUT / AE)	
AC max. voltage:	500 V _{RMS}
DC max. voltage:	1000 V _{RMS}
Current max.	
passive, cooling (Fan) off:	300 A _{RMS} (CW), 450 A _{RMS} (for 15 min)
active, cooling (Fan) on:	800 A _{RMS} (CW) (for 2 hours), see user manual, T _{AMB} ≤ 25 °C (cooling >20 min with EUT current off and fan on)
Test voltage:	1500 VDC 2 sec.
Simulated impedance (EUT):	1 μH 47.6 Ω ± 20% (jumper connected) 1 μH 50 Ω ± 20% (jumper removed)
DC resistance (AE / EUT):	0.5 mΩ
EUT / AE sockets:	16 mm bolt with fine screw nut (M16x1.5)
Connector chassis:	16 mm bolt with screw nut (M16)
RF socket:	Type-N, jack/ female 50 Ω
Connector for cooling:	coaxial connector (male, DC+ on inner pin)
Requirements for cooling:	12 VDC, approx. 1.1 A
Power supply for cooling:	12 VDC/ 2.5 A, length 1.8 m, coaxial connector (female) 5.5 x 2.5 mm

Mechanical specifications

Size (L X W x D):	365 mm x 203 mm x 203 mm
Weight:	approx. 6.5 kg

Environmental conditions

Classification	Indoor use only
Operating temperature	0 °C to +30 °C
Storage temperature	-10 °C to +60 °C
Relative humidity	up to 90% (no moisture condensation)

HV-AN 1uH-800-VW80300 HIGH VOLTAGE ARTIFICIAL NETWORK



View to the EUT port



View to the AE port

Example of HV-AN 1uH-800-VW80300 schematic

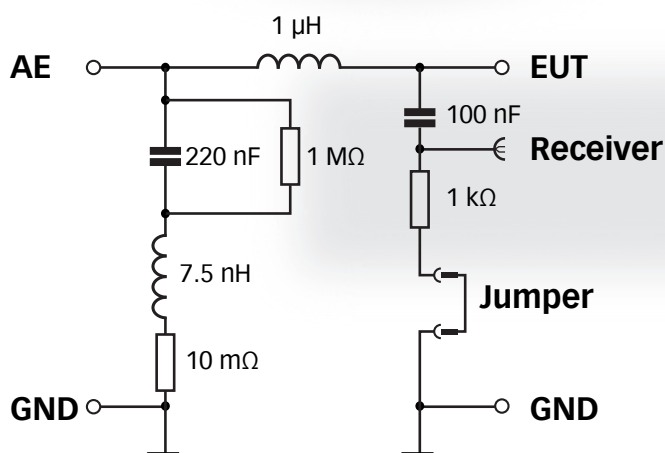

Model No. and options

Part number	Description
261409	HV-AN 1uH-800-VW80300 1 μH high voltage artificial network, 800 A, according to VW 80300
259607	SME HV-AN 500 Shielded metal enclosure for two HV-AN 500
257521	A 50-N Termination 50 Ohms, N type, male, 1 Watt, 4 GHz
259667	CAS HVAN500 Calibration set for HV-AN 500

AMETEK CTS Europe GmbH
Landsberger Str. 255 · 12623 Berlin · Germany
T +49 30 56 59 88 35 F +49 30 56 59 88 34
customer@ametek.com
www.ametek-cts.com

© August 2024 Teseq®

82-261409 E02 August 2024