



**MAIN FEATURES**

- 250 kVA/kW, upgradeable to 1 MVA / 1MW
- EV full vehicle testing ECE R10
- EV high voltage component testing
- 1500 VDC / 1000 A and 360 VAC / 236 A
- 4-quadrant operation with 100% source/sink and power recovery
- 1000 Hz frequency range & 1250 V/ms slew rate
- remote control and extensive test library

**PowerWave 250  
Electronic Power Source**

PowerWave is a high power, electronically controlled power sources suitable for applications where exceptional performance is required.

**Electric Vehicle testing according ECE R10**

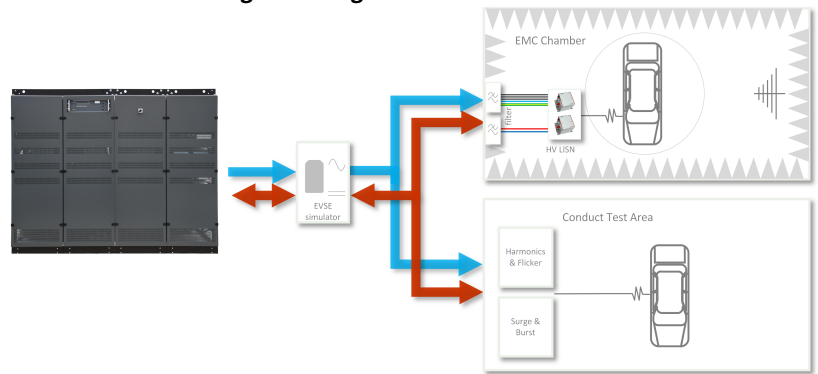

PowerWave is the ideal source to supply your **EMC chamber and conducted test area** with the power that is needed. It combines AC and DC in a compact footprint and allows charging in Mode 3 (AC) and Mode 4 (DC). With an additionally required charging station simulator (i.e. Comemso EVCA) various charging standards like Chademo, GB/T, CCS and Tesla are covered.

The adjustable output configurations, 1000Hz bandwidth and flexible on-board waveform generator allow PowerWave to simulate various grid configurations (single, split and three phase) and generate power anomalies. This includes frequency variations, phase shifts, phase unbalance, voltage variations and disturbances (i.e. flat-curve, harmonics, interharmonics etc.). These are ready to use in a large library with pre-programmed tests - included in the net.control software.

**EV High Voltage Component Testing**

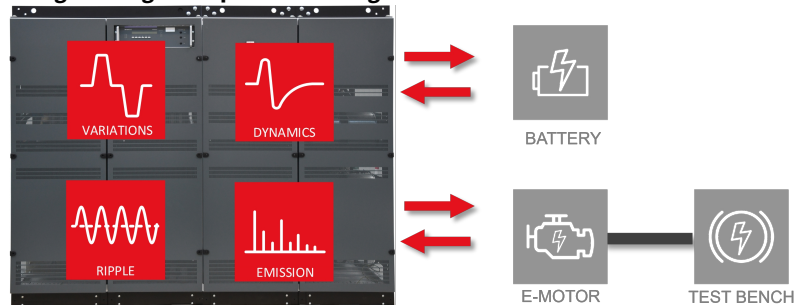

PowerWave is the perfect fit to test high voltage components up to 1500 VDC, i.e. electric drives, batteries and auxiliary components. It can not only be used as constant voltage source, but covers with its 1250 / ms slew rate challenging tests such as voltage variation and dynamics (i.e. ISO 21498, LV123, MBN 11123, VW 80300, Nissan 28400NDS91 and similar). PowerWave is a fully bi-directional source with 100% source /sink capabilities. This allows testing of electric drive systems in motor and generator mode as well as charging and discharging of HV batteries. The included power recovery function reduces dissipated heat and energy consumption.

**Other applications covered**

- grid simulator for solar inverter or charging station testing
- high power avionics & military component testing

**Power Recovery - reduced heat dissipation and energy consumption**

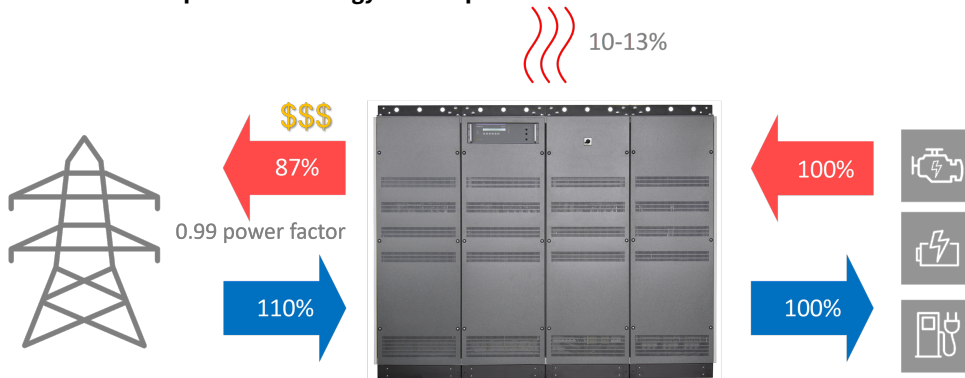

PowerWave modern topology incorporates an active front end (AFE) with power factor control (PFC). This allows fully bi-directional energy flow and power recovery to grid. Compared to a source with linear technology, PowerWave has a high efficiency and low internal losses. This leads to low heat dissipation and electricity consumption, which reduces cooling needs and saves energy costs. The PFC guarantees that power factor remains stable at >0.99 and by that, minimizes the apparent power and installation costs.

**The advantages of wide bandwidth and high slew rate**

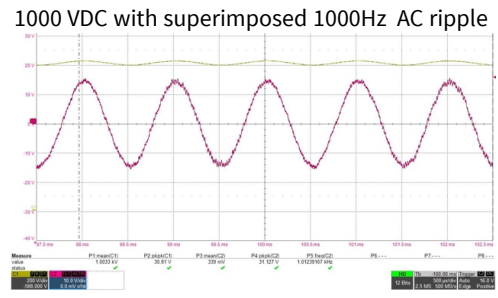
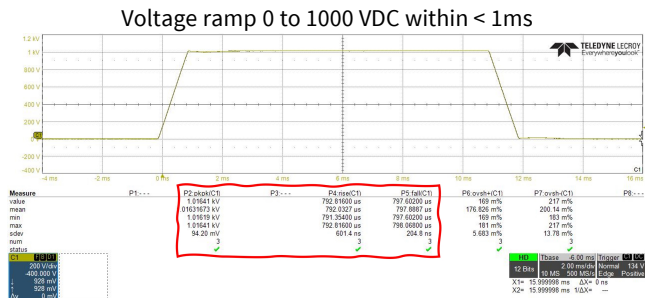

PowerWave is engineered for exceptional output performance. The slew rate of 1250 V /ms guarantees clean voltage ramps with very little over- and underswing. This is critical for high voltage component testing when tests with high dynamic supply voltage variations are performed. Thanks to its wide frequency range and combined DC+AC output, PowerWave can generate DC supply voltage with superimposed AC ripple. In combination with the ripple generator Ripple NX, tests according to ISO 21498, ISO 7637-4, LV123, MBN 11123, VW 80300 and many others can be performed - from 10 Hz up to 300 kHz.

**Wide voltage coverage with dual range output - 250 kW to 1 MW**

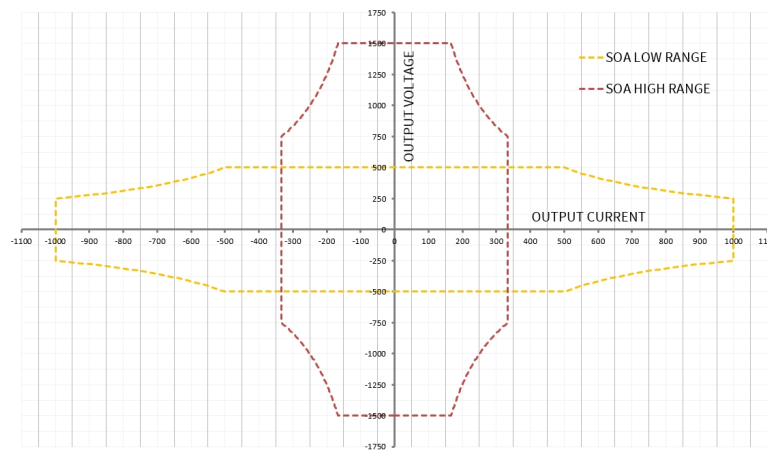

In electric vehicles, the voltage and power of the HV network vary with the brand, platform and model (typically 100 to 250kW, 150 to 1500VDC). With generally growing power requirements in the future. Thanks to its dual range output, PowerWave covers a wide voltage & current range and makes efficient use of the available power. It offers 250 kW in a single unit which can be extended up to 1'000 kW (upgradeable). This makes PowerWave the ideal choice for EV component testing where flexibility is important.

### Technical Specifications

Output AC	250 kVA, 3 x 360 V (line - neutral), 236 A per line
Output DC	250 kW High Range: max. 1500 V, max. 333 A Low Range: max. 500 V, max. 1000 A see power diagram for details
Number of Lines	3
Bandwidth	765 Hz
Frequency range	DC - 1000 Hz
THD @ 50/60Hz, max.	0.5 %
Voltage Accuracy	DC: $\pm 0.2\%$ of set value $\pm 0.15\%$ of full scale; AC: add $\pm 0.1\%$ of set frequency / 1000
Slew Rate max.	1250 V/ms
Isolation Voltage	L-PE: and N-PE: 1000 VAC / 1500 VDC

### General Specifications

	PowerWave 250-400	PowerWave 250-480
Display and Controls	2-line LCD, 40 characters	
Waveform Generator	Integrated waveform generator (segment & point)	
Operating Modes	Constant Voltage, Constant Current, Constant Resistance, Constant Power	
Programmable resistance	0 - 1000 m $\Omega$ , 1m $\Omega$ steps	
Current Limiter	separate source and sink limiters, RMS or PEAK, continuous or stop	
Safety	emergency stop, interlock, external relay control	
Protection	overvoltage, overcurrent, overtemperature, input voltage	
Output Connectors	copper bars	
Supply Voltage	3 x 400 V, +/- 10%, no neutral, 50/60 Hz	3 x 480 V, +/- 10%, no neutral, 50/60 Hz
Supply Current	475 A / line	396 A / line
Supply Connector	Screw connector, M12	
Dimensions	2380 x 1882 x 990 mm / 94 x 74 x 39 in	
Net Weight	2900 kg / 6394 lb	
Operating Environment	5°C - 35°C, 10% - 90% non-condensing, 86 kPa (860 mbar) to 106 kPa (1 060 mbar)	